

# AL125ULB

## Access Control Power Supply/Charger Board

Altronix AL125ULB two (2) output switching Power Supply/Charger converts a low voltage AC input into two (2) individually PTC protected 12VDC or 24VDC outputs.



AL125ULB

### Specifications

#### Input

Voltage 24VAC, 40VA from  
UL Listed, Class 2 transformer

#### Outputs

Voltage 12VDC or 24VDC selectable  
Current 1A supply current  
Other PTC protected. Rated @ 2.5A  
Short circuit and thermal overload protection  
Filtered and regulated

#### Back-up Battery *(not included)*

Type Sealed lead acid or gel type  
Failover Upon AC loss, instantaneous

#### Supervision

Supervised Fire Alarm Disconnect  
(Latching w/reset or Non-Latching)

#### Indicator (LED)

Unit Status Normal/No Output/Loss of AC/Triggered

### Agency Listings

UL Recognized component  
NFPA 101 (Life Safety)

### Physical and Environmental

Dimensions (L x W x H)  
Board: 3.8" x 3.0" x 1.5" (96.5mm x 76.2mm x 38.1mm)  
Shipping: 8" x 6" x 5" (203.2mm x 152.4mm x 127mm)

#### Weight (approx.)

Product: 0.25 lb. (0.11 kg)  
Shipping: 0.35 lb. (0.16 kg)

#### Temperature

Operating: 0°C to 49°C (32°F to 120°F)  
Storage: -20°C to 70°C (-4°F to 158°F)

#### Relative Humidity

85% +/- 5%.

#### BTU/Hr (approx.)

6 or 12 BTU/Hr.

### Lifetime Warranty

**AL125ULB**

Access Control Power Supply/Charger Board

**Dimensions and Drawing**

Board Dimensions (L x W x H approximate)

3.8" x 3.0" x 1.5" (96.5mm x 76.2mm x 38.1mm)

Mounting Holes' Tolerance: +/- 0.04 in. (1mm)

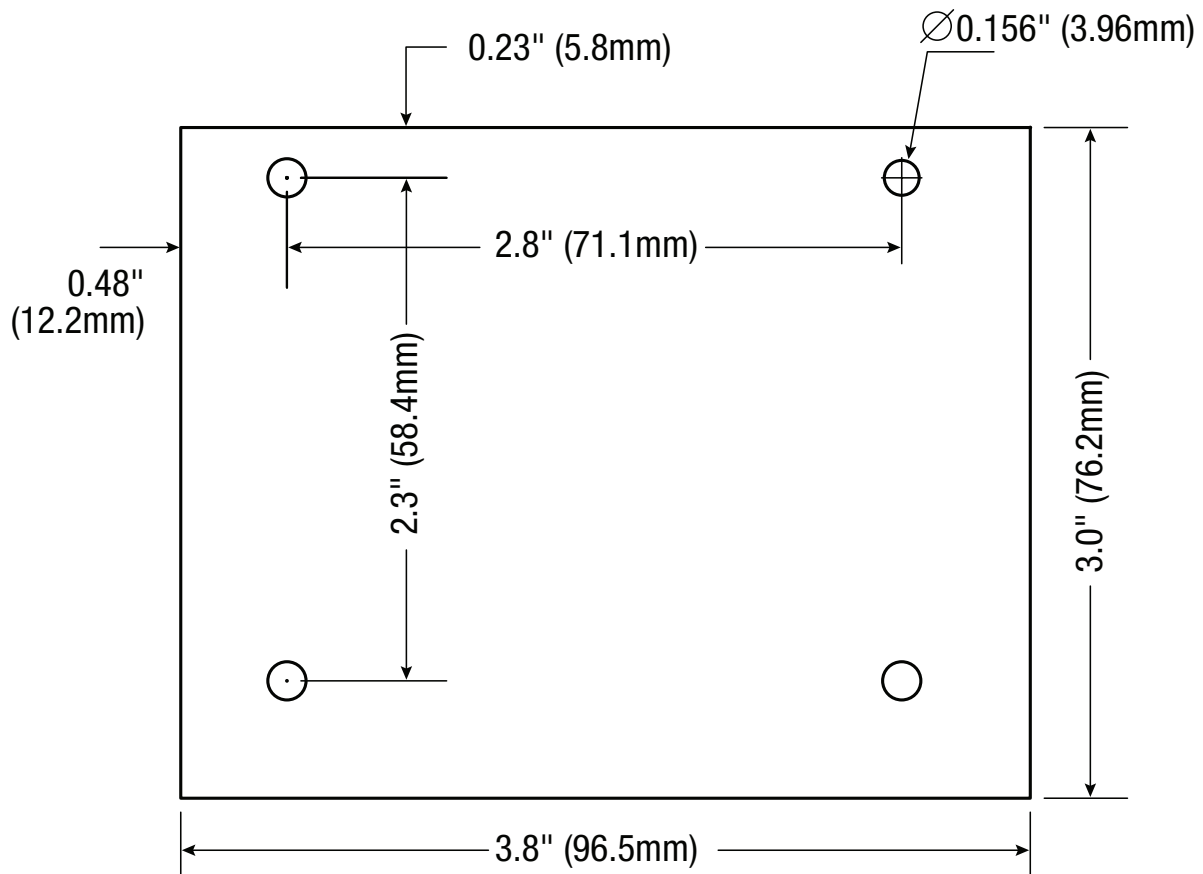
**Lifetime Warranty**

Altronix Corporation | 140 58th St | Brooklyn, NY 11220 USA

phone: +1 718.567.8181 | fax: +1 718.567.9056 | email: [info@altronix.com](mailto:info@altronix.com) | [www.altronix.com](http://www.altronix.com)