

How To Order Rim & Mortise Cylinders

Complete part numbers are required for all orders. To determine the correct part number, fill in the "X's" in sequential order.

1

100200 base part # example

Refer to pages 81-87 for descriptions and technical specifications to find the corresponding base part number.

2

H technology

H = M4
 P = M4 BiLevel
 T = M³
 J = M³ BiLevel
 S = M³ CLIQ
 W = Biaxial
 - = Original
 K = KM
 C = Classic CLIQ
 N = X4
 M = X4 CLIQ
 G = XT

3

05 finish

Refer to the inside back cover of this catalog for finish options.

4

M4 keyway

Insert keyway if known or contact Customer Service for help.

5

P pinning

S = Sub-Assembled (Uncombined)
 N = Sub-assembled,
 - No side pins (M4 only)
 - No slider (M3 only)
 P = Pinned (Combinated)
 M = Master Keyed
 R = Master Keyed
 - blade and side pins (Medeco 4 only)

6

Z01 cam or tailpiece

Refer to pages 83-84 for cam and tailpiece options.
 If not specified, Z01 for mortise and Y02 for rim will be supplied.

7

624 side pin code

(M4 only)

Insert side pin code if known or contact Customer Service for help.

BUILD A RIM & MORTISE PART #:

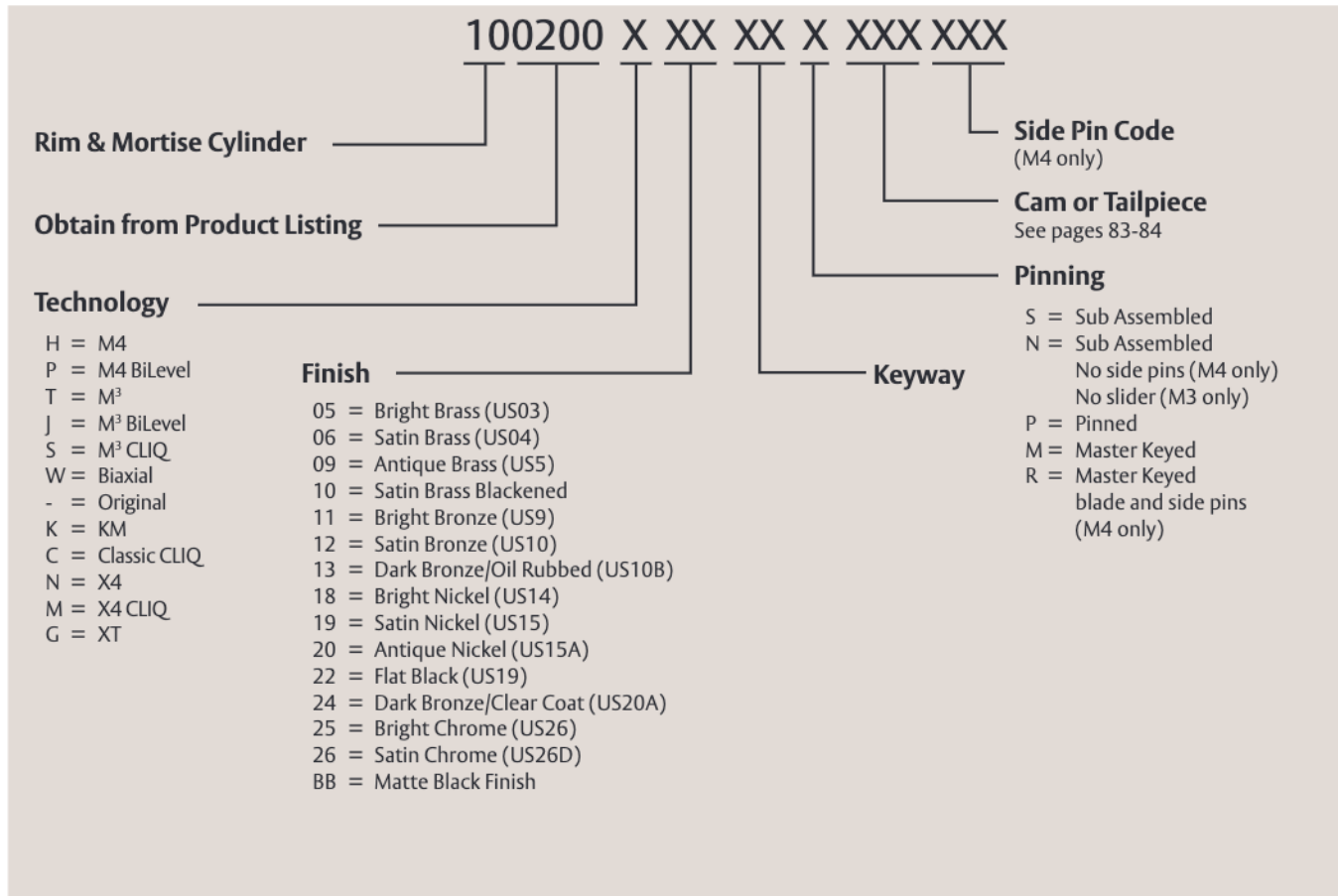

For legacy technology pricing, call Customer Service or visit Medeco.com.